

NETZSCH

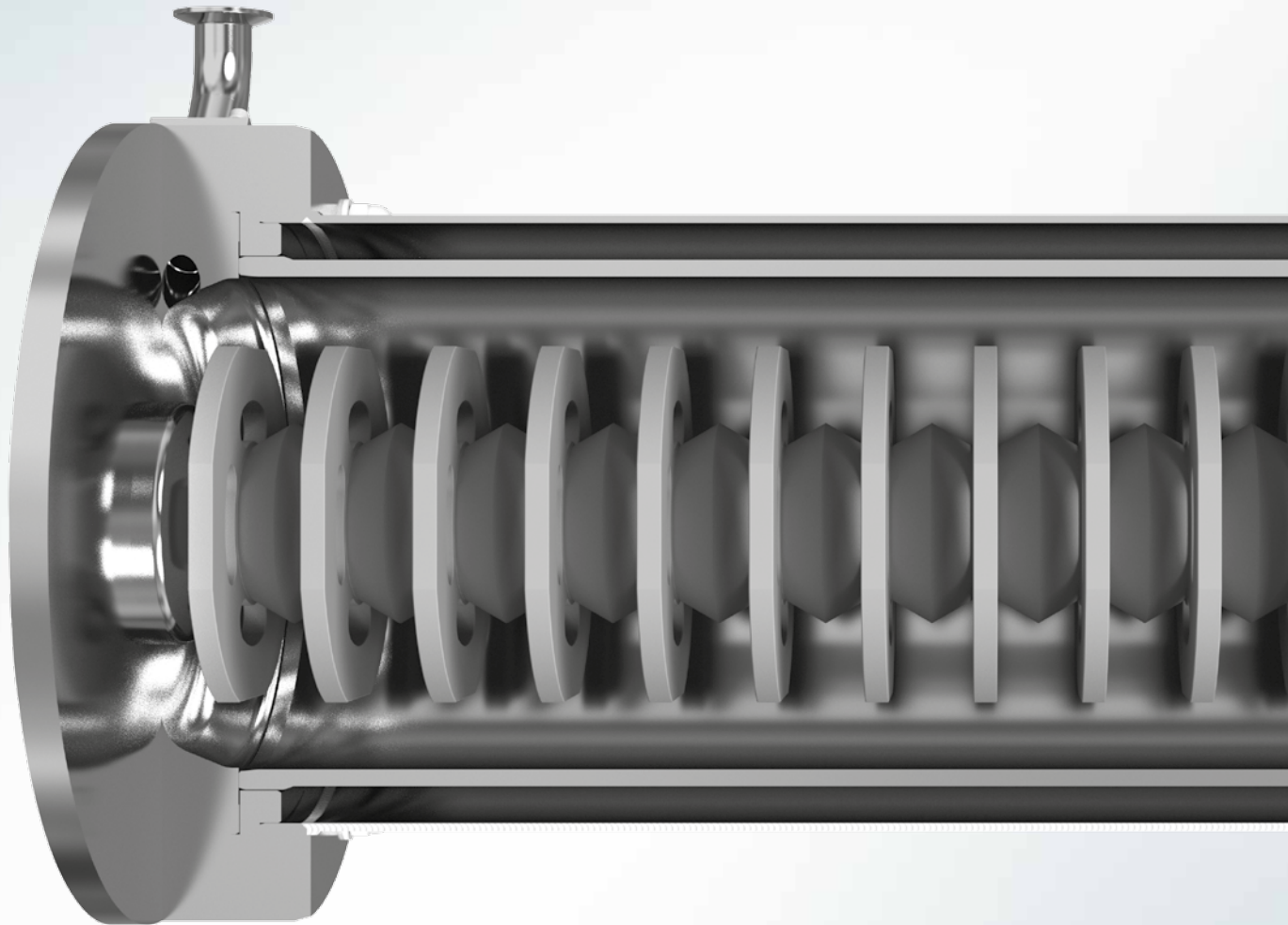

Discus Grinding System

The universal Grinding System

CHEMICAL INDUSTRY | a Business Field of
NETZSCH Grinding & Dispersing

NETZSCH *Discus* Grinding System

The universal Grinding System

Discus is the byword for high-performance agitator bead mills with disk agitator. The high length/diameter ratio, the different grinding disk geometries, the various material options, as well as the highly-efficient grinding bead separation system facilitate an application-specific design of this machine for your particular task.

The highest throughput rates with significantly narrower residence time distributions and therefore more intensive grinding with consistent stress intensity are guaranteed with the optimized *Discus* disk agitator combined with the NETZSCH DCC® separation system.

The *Discus* grinding system optimizes the movement of the grinding media so that higher power input and production output are achieved with a simultaneous increase in grinding efficiency.

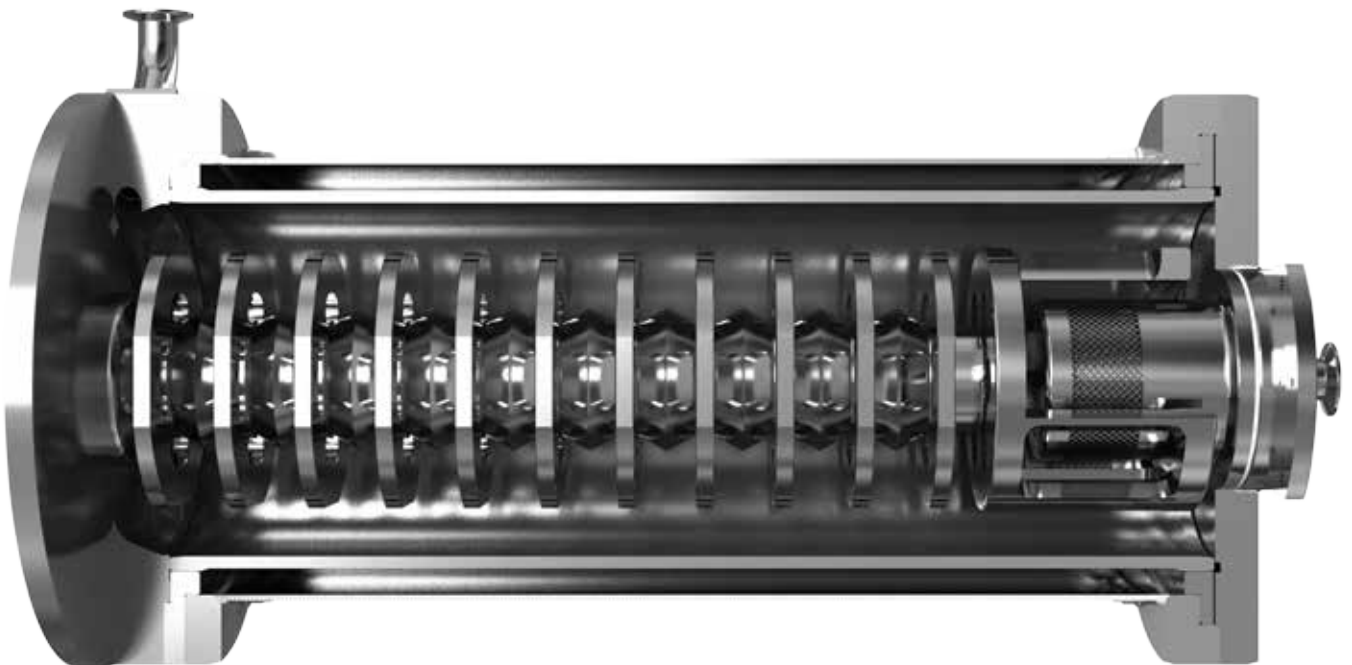

Sizes – from the Lab to large-scale Production

| Models | Capacity Factor | Batch size [l] | Drive power [kW] | Typical throughput rate [kg/h] |
|-----------------------------------|-----------------|----------------|------------------|--------------------------------|
| <i>LABSTAR</i> <i>ALPHALAB</i> | 0.07 | 1,5 - 5 | 2.2 - 3 | 5 - 50 |
| <i>Discus 4</i> | 0.25 | 10 - 100 | 5.5 - 7.5 | 18 - 180 |
| <i>Discus 20/30</i> | 1 / 1.2 | 100 - 500 | 18.5 - 22 | 70 - 750 |
| <i>Discus 60</i> | 2.0 | 200 - 1000 | 37 | 140 - 1500 |
| <i>Discus 150</i> | 4 | 500 - 2500 | 75 | 250 - 2500 |
| <i>Discus 200</i> | 6 | 1000 - 10000 | 75 - 90 | 420 - 4200 |
| <i>Discus 300</i> | 8 | > 2000 | 90 - 132 | 560 - 5600 |
| <i>Discus 500</i> | 12 | - | 160 - 200 | 840 - 8400 |
| <i>Discus 1000</i> | 20 | - | 315 - 355 | 1400 - 14000 |

Your Benefits

- Reliable scale-up
- Variety of sizes
- High length/diameter ratio
- Highly-efficient grinding media separation system
- Optimum cooling water flow
- Inner pipe of grinding tank made of NETZSCH-CERAM C
- Highest throughput rates
- Significantly narrower residence time distribution
- Intensive grinding with consistent stress intensity
- Highest power input
- Low specific energy requirement

NETZSCH *DISCUS* – Increase your Power In

Variable Power Density

With the variable disk geometries of the new Discus grinding system, the power density in the grinding chamber can always be adjusted to the requirements of the product.

Maximum Volume Throughput

In circulation mode, the required number of circuits is achieved very quickly due to the extremely high volume throughput.

Optimized Cooling

The highest cooling efficiency is obtained through the use of new materials and optimum utilization of the available cooling surface.

Various Grinding Bead Sizes

Select the right size NETZSCH *ZETA*[®]-*BEADSPLUS* for your process.

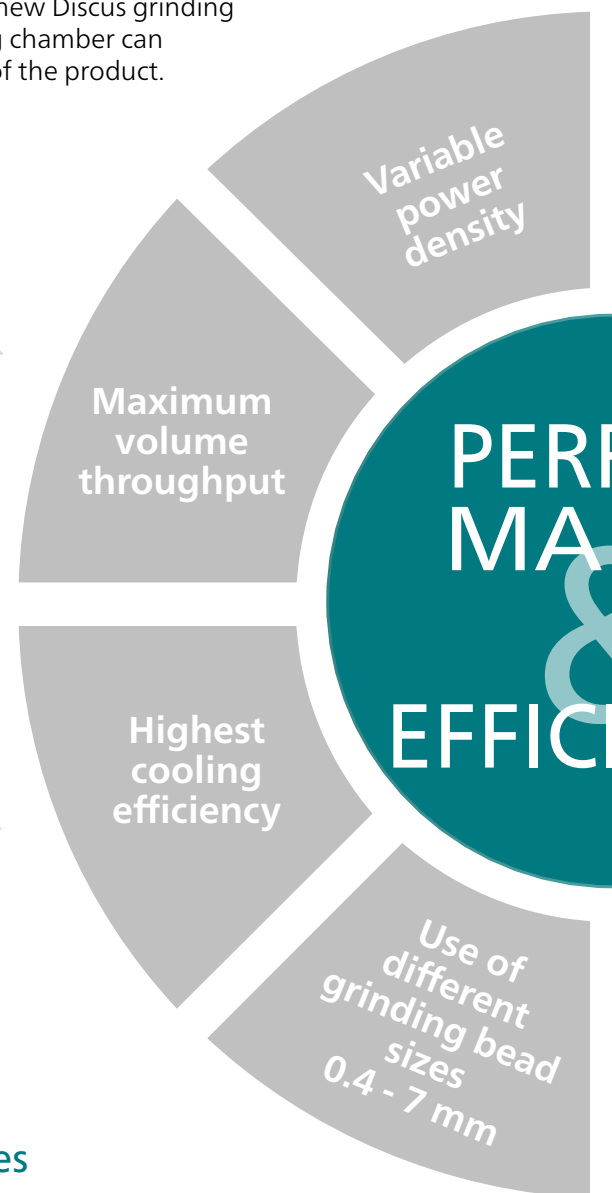

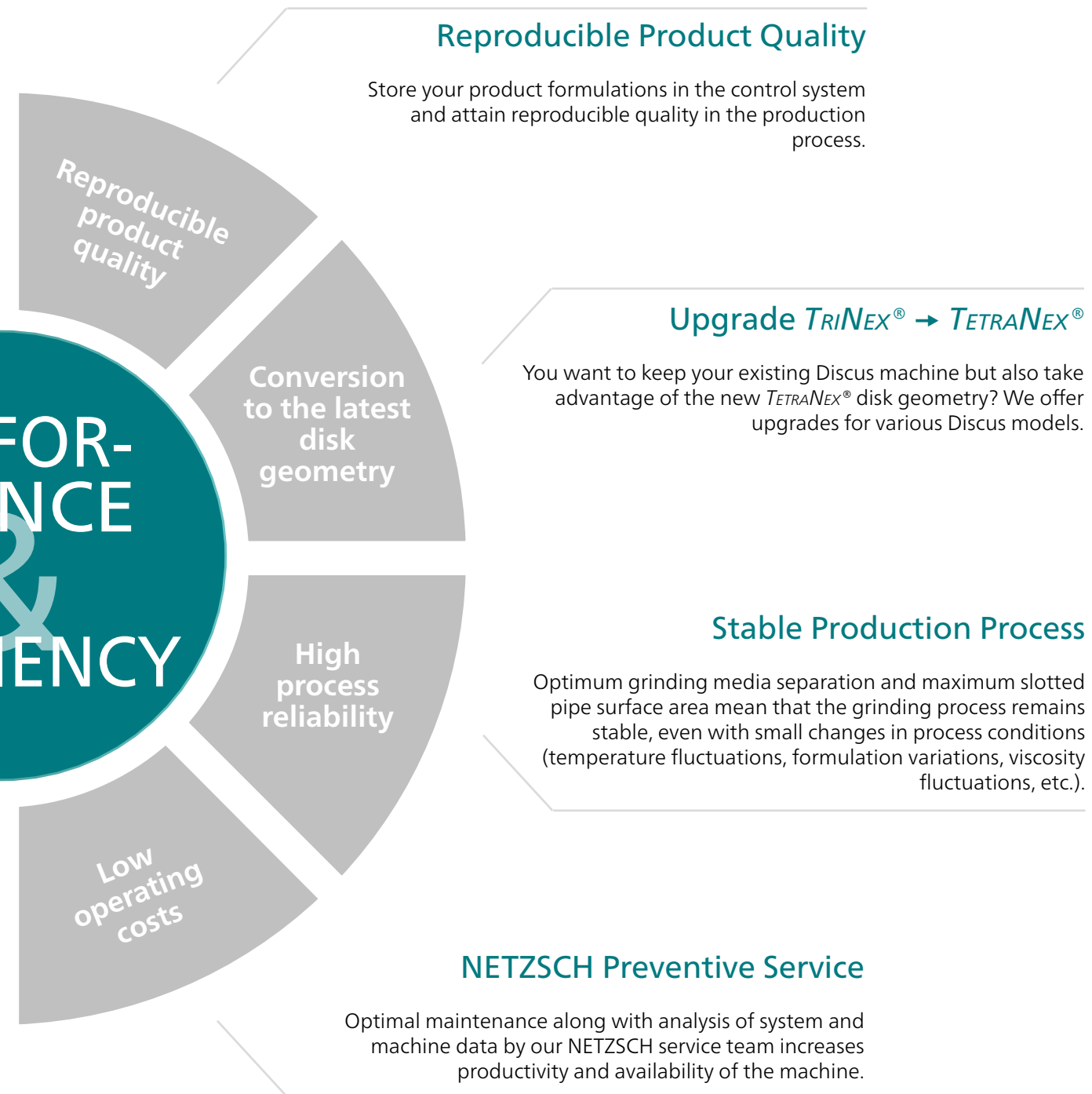

NETZSCH *DISCUS* Grinding System

The Separation System is the Key

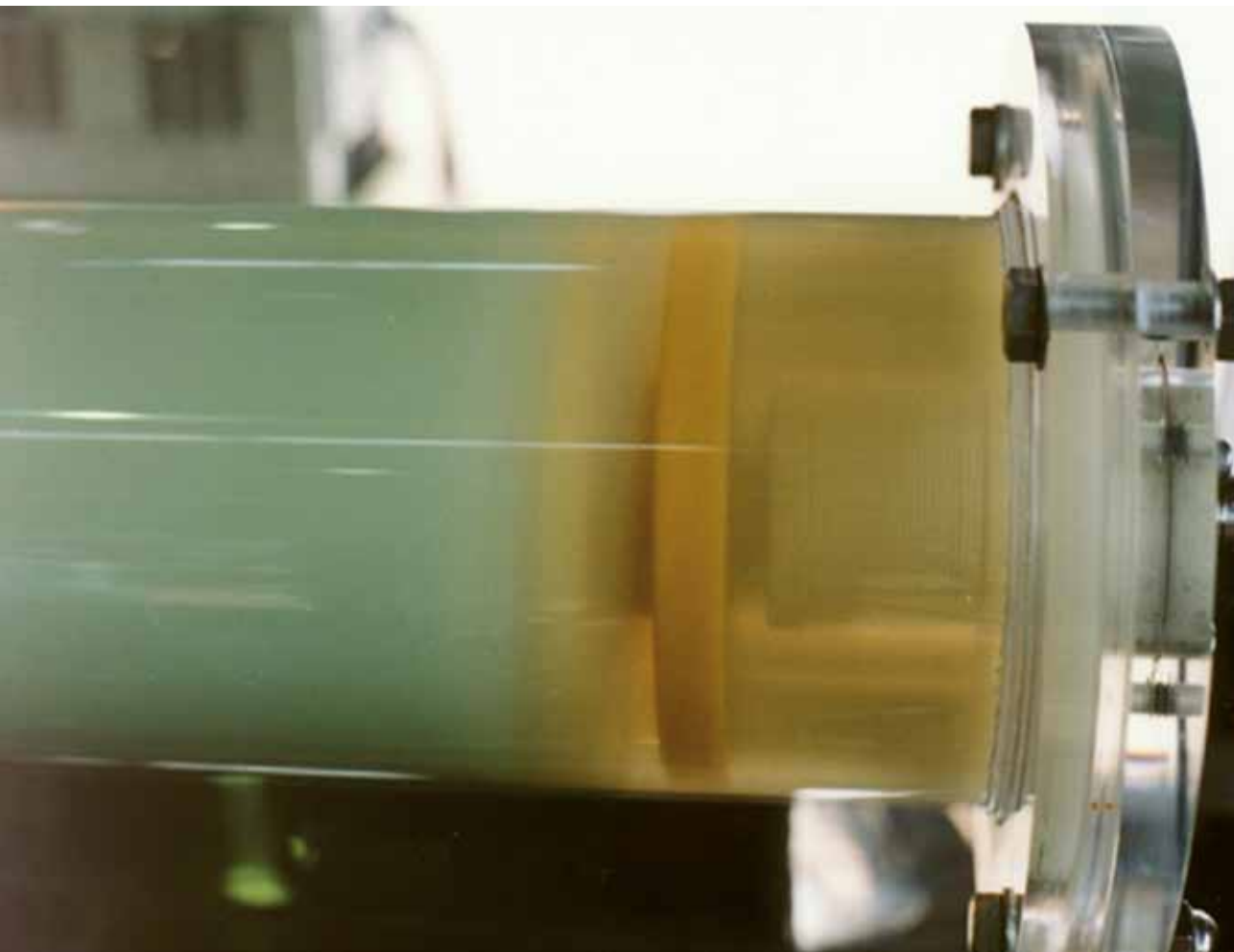

Mode of operation of the DCC preclassifying separation system in an horizontal bead mill with disk agitator with 0.3 mm glass grinding beads at a water flow rate of 600 l/h

The Model DCC Preclassification System

The highly efficient, dynamic centrifugal separation system facilitates the use of grinding beads of various densities, matched to the application. In addition, it allows the use of grinding beads up to 0.4 mm in diameter. The separation system ensures that the mill can be operated far below the critical point of grinding bead compression, even for products with challenging rheological properties.

This means that operational performance is extremely stable, shutdown due to overpressure and exceeding the permitted temperature limits is avoided and grinding media wear is minimized. The classifying rotor increases the service life of the separation screen and thus minimizes maintenance work and downtimes.

How it works

- Product enters the preclassification area through the axial gaps in the last grinding disk
- Entrained grinding beads are centrifuged outward in this area, while the product enters the separation chamber axially through the openings in the pre-classifier disk
- Formation of a circulation flow through the rotor, which counteracts the axial flow of the material being processed

Focus on your Benefit

- Use of very small grinding media even with high product viscosities and throughput rates
- Maximum relief of load on the screen through the provision of a pre-classifier disk

NETZSCH *DISCUS* Grinding System

Optimum Grinding Bead

*TETRA*NEX® – The grinding system for optimum energy input

The NETZSCH *DISCUS* agitator bead mills are equipped with the *TETRA*NEX® grinding system. The *TETRA*NEX® grinding disk, which replaces the familiar *TRI*NEX® grinding disk, is available in the standard design and in the *TETRA*NEX® Plus version. While the front side of the standard version is smooth, just like the *TRI*NEX® version, the *TETRA*NEX® Plus disk has special activation elements. These activate the grinding beads reciprocally in the axial direction, which leads to increased contact between the grinding beads and thus to more effective grinding processes.

Your Benefits

Thanks to the new geometry and with application-oriented, optimized mounting of *TETRA*NEX® disks in the standard and *TETRA*NEX® PLUS version, the power input of the mill can be increased up to 30%. This leads to a significant increase in production output.

However, because temperature limits often limit an increased power input during processing, NETZSCH also offers the *COOL PLUS* package. This package includes a grinding tank with an inner pipe made of NETZSCH *CERAM C*.

Combined with an optimized cooling water flow, its thermal conductivity, which is several times higher than that of steel, facilitates maximum heat transfer between the product and the cooling water and thus a low product temperature with maximum grinding efficiency.

The combination of the *DISCUS* grinding system and the *COOL PLUS* package facilitates increased production output with optimal cooling, which also guarantees enhanced production reliability with respect to quality and adherence to the permissible temperature limits.

COOL PLUS Package

- Grinding tank with inner pipe made of NETZSCH-*CERAM C*
 - Higher thermal conductivity compared to steel
 - High degree of hardness and wear resistance
- Optimized cooling water flow for maximum heat transfer

Activation

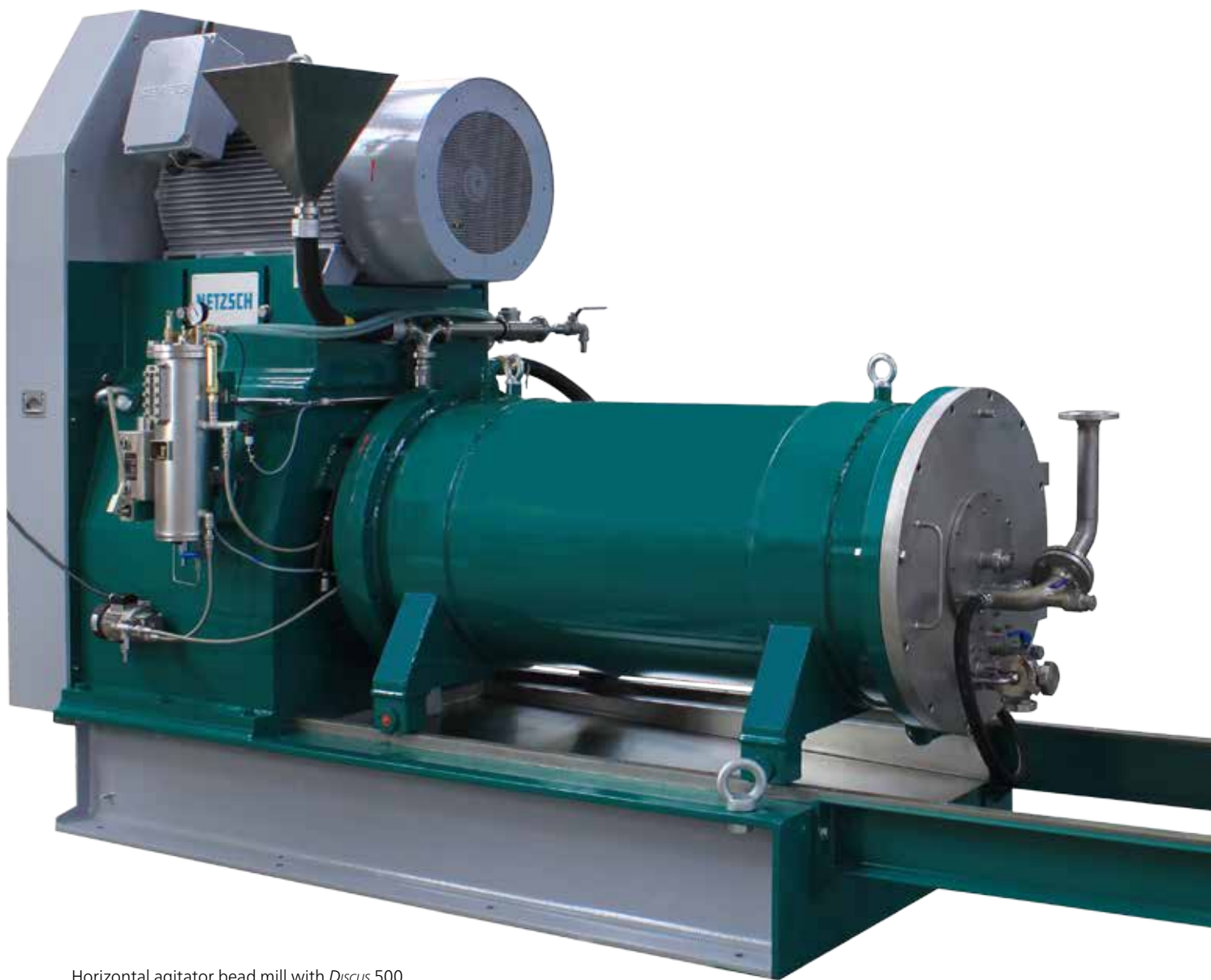

Horizontal agitator bead mill with *Discus* 500 disk agitator

NETZSCH *DISCUS* Grinding System

Specifically matched grinding chamber design & ap

Material options for every product

In order to satisfy the requirements of the broadest array of products and to guarantee product compatibility, we offer grinding tanks and agitator shafts made from a variety of materials. Matching the grinding system material to the product properties facilitates low-wear operation of the mill. Contamination of the product is thereby avoided. This leads to an enormous expansion of potential applications for the machine. The inner pipes of the grinding tank that come in contact with the product can be exchanged quickly and easily on site. This means you incur lower investment and storage costs and you experience the greatest possible flexibility in adapting to new product groups.

Range of grinding tank materials:

- Chilled cast iron
- Wear-resistant steel
- Stainless steel
- Aluminum oxide
- NETZSCH-CERAM Z
- NETZSCH-CERAM N
- NETZSCH-CERAM C
- Silicon carbide
- NElast
- Polyethylene
- Rubber

Focus on your Benefit

- Selection criteria are: resistance to solvents, temperature sensitivity of the product and wear resistance or low-contamination processing
- For every product requirement there is a suitable grinding chamber material or, if necessary, material combination available to you
- It is often possible to convert an existing LME agitator bead mill to a different grinding chamber material and the *DISCUS* grinding system – speak with our specialists
- Minimal maintenance costs



Applications

Applications

- Printing inks
- Coatings
- Pigments
- Textile dyes
- Magnetic coatings
- Paper coatings
- Fillers
- Pesticides
- Ores
- Minerals
- Technical and consumer ceramics
- Ceramic masses and glazes
- Pharmaceuticals
- Cosmetics
- Foods: e.g. cocoa, chocolate, chocolate compounds
- Biotechnology: cell disruption

Business Unit Grinding & Dispersing – The World's Leading Grinding Technology

NETZSCH-Feinmahltechnik GmbH
Selb, Germany

NETZSCH Lohnmahltechnik GmbH
Bobingen, Germany

NETZSCH Premier Technologies,
LLC. Exton PA, USA

NETZSCH Indústria e Comércio de
Equipamentos de Moagem Ltda.
Pomerode, Brazil

NETZSCH Technologies India
Private Ltd.
Chennai, India

NETZSCH Trockenmahltechnik GmbH
Hanau, Germany

NETZSCH España, S.A.U.
Terrassa/Barcelona, Spain

NETZSCH Mastermix Ltd.
Lichfield, Great Britain

NETZSCH (Shanghai) Machinery
and Instruments Co., Ltd.
Shanghai, China

NETZSCH FRÈRES S.A.R.L.
Arpajon, France

NETZSCH Vakumix GmbH
Weyhe-Dreye, Germany

AO NETZSCH Tula
Tula, Russia

NETZSCH Korea Co., Ltd.
Goyang, Korea

NETZSCH Makine Sanayi ve
Ticaret Ltd. Sti.
Izmir, Turkey

ECUTEK S.L.
Barcelona, Spain

The NETZSCH Group is a mid-sized, family-owned German company engaging in the manufacture of machinery and instrumentation with worldwide production, sales, and service branches.

The three Business Units – Analyzing & Testing, Grinding & Dispersing and Pumps & Systems – provide tailored solutions for highest-level needs. Over 3400 employees at 210 sales and production centers in 35 countries across the globe guarantee that expert service is never far from our customers.

NETZSCH-Feinmahltechnik GmbH
Sedanstraße 70
95100 Selb
Germany
Tel.: +49 9287 797 0
Fax: +49 9287 797 149
info.nft@netsch.com

NETZSCH®

www.netsch.com